

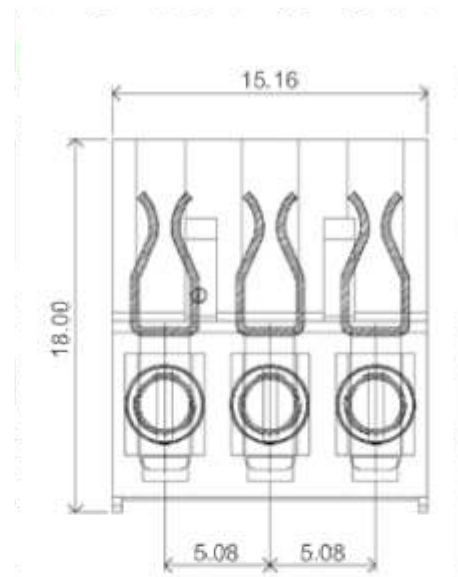

Manufacturer of PCB Terminal Blocks, Fuse Holders, Barrier Terminals, & Switches

Screw Type (Cage-Clamp Pluggable Design) Connectors

Series COM 90 F

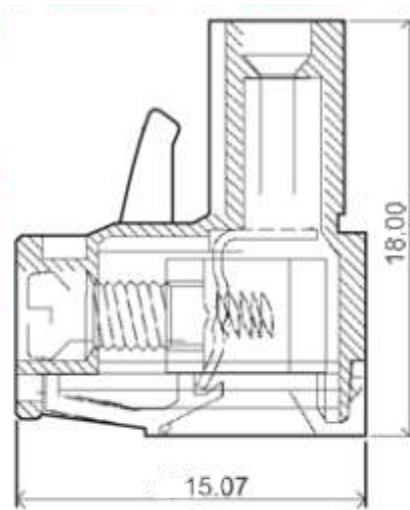

TECHNICAL SPECIFICATIONS :

Pitch	: 5.08 mm
Nominal Rating	: 15A/300V
Dielectric Strength	: > 2kV
Moulded Material	: Polyamide (Nylon) 66 - UL94 V0 or V2
Insulation Resistance	: > 1000 M Ω @ 500 Vdc
Terminal	: Tin Plated Copper Alloy
Wire Cage	: Nickel Plated Brass
Screw	: M3 x 0.50 mm
	: Brass Nickel Plated Suffix "P" : MS Trivalent Zinc Plated Suffix "C"
Wire Size	: 2.5 mm ²
Maximum Torque	: 0.50 - 0.60 Nm

Approval Data

- UL : 300V / 12A / 28-12 AWG
- cUL : 300V / 12A / 28-12 AWG
- CE : 300V / 15A / 28-12 AWG

ORDERING CODE

Series	Poles	Grade
--------	-------	-------

→ COM 90/n F P ←
n = Number of poles : 2 To 14
Grade : P or C

- P = Professional Grade
- C = Economy Grade

